

Anomalous Phenomena, Physics, and Computer Science

Richard Shoup

Interval Research
Palo Alto, CA
shoup@interval.com

R. Shoup

Copyright © 1997 - All Rights Reserved

Interval Research 

Physics & Computer Science

- Complementary disciplines
 - Physics: understanding this universe
 - Computer Science: building new universes
applied mathematics + engineering
- Fundamental concepts the same
 - Space, Time, Objects, Events, Causality, etc

"Some Principle uniquely right and uniquely simple must, when one knows it, be also so compelling that it is clear the universe is built, and must be built, in such and such a way, and that it could not possibly be otherwise."

-- John A. Wheeler in Gravitation

R. Shoup

Interval Research 

Fundamentals

- Quantum Mechanics
 - Highly successful, but absurd, not understood
 - Requires rethinking fundamental concepts
 - Room for weirdness, but maybe not where expected
- Computer Science
 - 50 years, still using von Neumann's architecture and Turing's theory
 - Current paradigms inadequate for 21st century:
Highly concurrent, distributed, interactive systems
 - Reconfigurable "soft" hardware
 - Unify hardware and software domains

R. Shoup

Interval Research 

Anomalies & Physics

- "New Age" physics
 - "Superluminal quantum connectedness seems to be, on the surface at least, a possible explanation for some types of psychic phenomena. Telepathy, for example, often appears to happen instantaneously, if not faster."
 - " ... Bell's theorem ... proves that quantum theory requires connections that appear to resemble telepathic communication." -- Gary Zukav, The Dancing Wu Li Masters
- Mainstream physics
 - "Needless to say, [paranormal phenomena such as precognition] would be just as upsetting in quantum mechanics as in classical physics; if genuine, they would require a complete revamping of the laws of nature as we know them." -- Murray Gell-Mann, The Quark and the Jaguar

R. Shoup

Interval Research 

Anomalies & Physics - Myths

- Telepathy doesn't diminish with distance.
- Faster-than-light velocities or causality backwards in time are prohibited.
- Measurement causes the particle to "choose", definite.
- Quantum "collapse of the wave function" is random.
- ...
- Aliens couldn't or wouldn't spend the time or energy to come here from another star system.
- Alien abductions are illogical, don't make any sense and are thus likely imagination, temporal lobe disorders, etc.

R. Shoup

Interval Research 

Turing Anticipates Objections to AI (1960)

1. The Theological Objection (a Soul)
2. The "Heads in the Sand" Objection (Fear)
3. The Mathematical Objection (from Gödel)
4. Argument from Consciousness
5. Arguments from Various Disabilities
6. Lady Lovelace's Objection (Originality)
7. Argument from Continuity in the Nervous System
8. Argument from Informality of Behavior
9. Argument from Extra-Sensory Perception

R. Shoup

Interval Research 

Can Machines Think?

"The question ... I believe to be too meaningless to deserve discussion. Nevertheless, I believe that at the end of the century the use of words and general educated opinion will have altered so much that one will be able to speak of machines thinking without expecting to be contradicted." -- Alan Turing, 1950.

Deep Blue beats Kasparov - May 11, 1997

Computers vs. Nature

Computing Systems

- serial, sequential
- digital, discrete
- singular, brittle
- centralized, concentrated
- linear, controlled
- homogeneous
- mechanical, intermittent
- difficult, arcane
- designed, crafted

Natural Systems

- highly parallel, concurrent
- analog, continuous
- redundant, resilient
- distributed, pervasive
- non-linear, chaotic
- heterogeneous
- alive, continuous
- accessible, familiar
- self-organizing, evolving

Which is a better match to human beings and their needs?

R. Shoup

Interval Research



R. Shoup

Interval Research



First Distinction

- First Thing -- Simplicity Itself
- Pure difference, discrimination
- Pure form, no interpretation yet
- Smallest possible, unavoidable step from the Void
- Both object and action

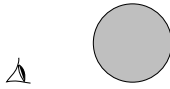

"The fundamental delusion of humanity is to suppose that I am here and you are out there." -- Yasutani Roshi

R. Shoup

Interval Research



Second Distinction

- Two possibilities
 - a) outside - symmetrical, cardinality
 - b) inside - asymmetrical, ordinality
- Allows first contradiction, paradox

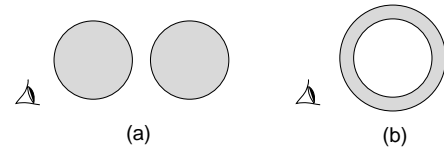

R. Shoup

Interval Research



Combinational Logic is Timeless

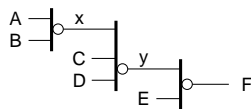

$$F = (((A \vee B) \vee C \vee D) \vee E)$$

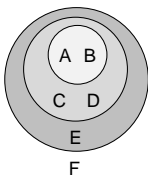

R. Shoup

Interval Research



Classic Paradoxes

- Epimenides (logic)
 - "I am lying." ("This statement is False.")
- Russell (set theory)
 - The set of all sets not containing themselves.
- the Barber (set theory or logic)
 - Barber shaves all men who don't shave themselves.
- Berry (number theory)
 - The smallest number not specifiable in less than N words.
- Gödel (logic/number/proof theory)
 - "This statement is unprovable."
- Turing (computability)
 - "This machine doesn't halt."

R. Shoup

Interval Research



Self-Reference - the Origin of Time

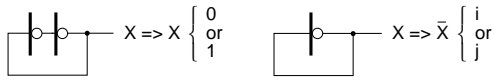

X_{in} _____

X_{out} _____

Autology (Memory)

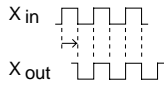

Paradox (Clock)

R. Shoup

Interval Research 

4-Valued Logic Holds Paradox

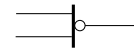
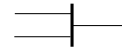
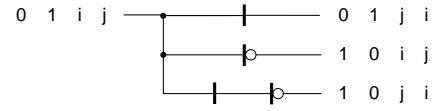

	0	1	i	j
0	0	0	1	j
1	1	1	1	1
i	i	j	1	j
j	j	i	1	1

	0	1	i	j
0	1	0	i	j
1	0	0	0	0
i	i	0	i	0
j	j	0	0	j

R. Shoup

Interval Research 

i : Logic :: √-1 : Reals

Logic

$$x = \sim x$$

$$x = i \text{ or } j$$

Real Numbers

$$x = -1/x \quad (x^2 = -1)$$

$$x = \pm\sqrt{-1}$$

R. Shoup

Interval Research 

Distribution

$$A \wedge (B \vee C) \stackrel{?}{=} (A \wedge B) \vee (A \wedge C)$$

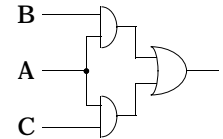
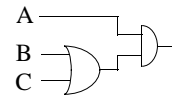

- Multiple reference in different contexts
- Problem is not distribution, but non-isolation

R. Shoup

Interval Research 

Logic & Making Sense

- Paradox, imaginary truth values
- Superposition & contradiction
- Distribution vs Quantum Logic
 $A \wedge (B \vee C) = (A \wedge B) \vee (A \wedge C)$
- Traditional Logic is classical, non-interacting

R. Shoup

Interval Research 

Square Root of NOT

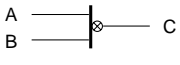

⊗	0	1	i	j
0	0	1	i	j
1	1	0	j	i
i	i	j	1	0
j	j	i	0	1

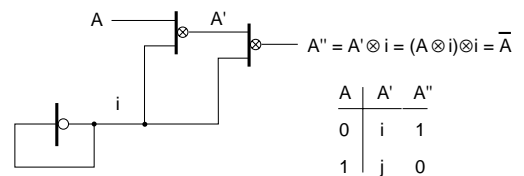

R. Shoup

Interval Research 

Link Theory (Etter)

- Compound relations
 - Case tables as in a Relational Database
- Case count: sum of possibilities
 - Negative cases -> interference
- Link of tables \Leftrightarrow Multiply by transformation matrix
- Not explained
 - How to get started? What is the theory *about*?
 - How to get negative case counts?
 - How to get apparent randomness/choice?

"An elementary particle is not an independently existing, unanalyzable entity. It is, in essence, a set of relationships that reach outward to other things." -- Henry Stapp

R. Shoup

Interval Research 

Linking Two NOTs - classical

$$\begin{array}{c|c} a & b \\ \hline 0 & 0 \\ 0 & 1 \\ 1 & 0 \\ 1 & 1 \end{array} \oplus \begin{array}{c|c} a' & b' \\ \hline 0 & 1 \\ 1 & 0 \\ 1 & 1 \\ 1 & 0 \end{array} \Rightarrow \begin{array}{c|c|c|c} a & b & a' & b' \\ \hline 0 & 1 & 0 & 1 \\ 0 & 1 & 1 & 0 \\ 1 & 0 & 0 & 1 \\ 1 & 0 & 1 & 0 \end{array} \Rightarrow \begin{array}{c|c|c} a & b' & n \\ \hline 0 & 0 & 1 \\ 1 & 1 & 1 \end{array}$$

$$\begin{bmatrix} 0 & 1 \\ 1 & 0 \end{bmatrix} \begin{bmatrix} 0 & 1 \\ 1 & 0 \end{bmatrix} \Rightarrow \begin{bmatrix} 1 & 0 \\ 0 & 1 \end{bmatrix}$$

R. Shoup

Interval Research 

Linking Two Sqrt(NOT)s - interference

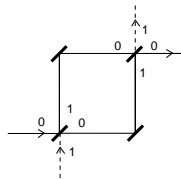

$$\begin{bmatrix} 1 & 1 \\ -1 & 1 \end{bmatrix} \begin{bmatrix} 1 & 1 \\ -1 & 1 \end{bmatrix} \Rightarrow \begin{bmatrix} 0 & 2 \\ -2 & 0 \end{bmatrix}$$

$$\begin{array}{c|c|c} a & b & n \\ \hline 0 & 0 & 1 \\ 0 & 1 & 1 \\ 1 & 0 & -1 \\ 1 & 1 & 1 \end{array} \oplus \begin{array}{c|c|c} a' & b' & n' \\ \hline 0 & 0 & 1 \\ 0 & 1 & 1 \\ 1 & 0 & -1 \\ 1 & 1 & 1 \end{array} \Rightarrow \begin{array}{c|c|c} a & b' & n' \\ \hline 0 & 0 & 0 \\ 0 & 1 & 2 \\ 1 & 0 & -2 \\ 1 & 1 & 0 \end{array}$$

R. Shoup

Interval Research 

Connecting Physics & Computing

- Sqrt(NOT) - logic and physics
- Link Theory - relational database -> QM matrices
- NMR Quantum computer (Gershenfeld & Chuang)
 - "coffee cup" + magnetic fields
 - ≤ 4 Qbit ops, ~ 1 Hz. operational at room temperature
 - table-top version?
 - matter in states never before seen
 - <http://feynman.stanford.edu/qcomp/>

R. Shoup

Interval Research 

Conclusions

- New fundamental mathematics common to Physics and Computer Science is both necessary and desirable
- Rethink concepts of Space, Time, Causality, "Sense"
- Paranormal phenomena can be explained within the framework of QM, but care must be taken
- Speculation: Quantum RNGs can be influenced strongly and reproducibly, but not "causally"
- Speculation: Quantum computer circuits will exhibit some form of psychic phenomena

R. Shoup

Interval Research 