

Anomalies and Constraints -

Can clairvoyance, precognition and psychokinesis
be accommodated within known physics?

RICHARD SHOUP

*Boundary Institute
Los Altos, California
shoup@boundaryinstitute.org*

Abstract -- In this paper, we consider the unnecessarily antagonistic relationship between anomalies such as psychic phenomena (“Psi”) and theoretical physics. Characteristics of Psi are discussed along with categories of possible explanation and mechanisms. A hypothetical Psi experiment is created to explore the implications of random processes in which constraints are present, one of which may be "on the future". A simple rotation of the experiment diagram suggests nonlocality phenomena in quantum physics. A revision of our thinking about the concepts of causality and randomness are argued as key to a deeper understanding of Psi and the quantum realm in general.

Keywords: psi, physics of psi, physics, time, causality, relation, correlation, RNG, random number generator, randomness, quantum, EPR, Bell’s inequality.

Introduction

In order to achieve a true understanding of anomalies such as psychic phenomena (“Psi”), we are going to have to give up a few things.

The persistent puzzle is that Psi, now well established in the laboratory as well as in everyday experience (Radin, 1997a), has generally been considered to be in serious conflict with physical theory painstakingly assembled and verified over centuries. In order to extricate ourselves from this conundrum, rather than postulating some radical new physics, we need to challenge and perhaps give up some of the assumptions that lurk, often unrecognized, beneath our existing view of the world. Key to the development and acceptance of Relativity was relinquishing our cherished common-sense notions of absolute space and time in favor of a more general concept of spacetime. The Mach/Einstein revolution took place not by invalidating and replacing Newtonian

mechanics, but by reaching for something deeper and more fundamental beneath it, and we believe the current situation is similar.

Toward these ends, we will focus first on those characteristics of Psi that are most disturbing and salient, and try to see what their presence implies for the necessary physical explanations. A simple hypothetical Psi experiment is then created and analyzed to show that by recasting the assumptions of the problem and adopting a relational approach we can easily produce effects that could be taken as Psi phenomena.

The nature and importance of Psi

Traditionally, Psi phenomena have been classified into telepathy (mind-to-mind communication), clairvoyance (knowledge of distant events or conditions), precognition (knowledge of the future), and psychokinesis (mind over matter). However, these categories and descriptions are now well out of date, misleading, and arguably an impediment to greater understanding. From decades of experimental exploration, it has become increasingly clear that these categories are not clearly separable, and are in fact manifestations of a deeper reality yet to be fully appreciated.

Important properties of Psi, strongly suggested by the evidence, include

- Space/distance independence
- Time/order independence (clairvoyance vs. precognition)
- Complexity independence (goal orientation)
- Experimenter effect (belief, audience)
- Selectivity (which target?), both sensing & affecting
- Small effects (in principle?)

Perhaps the most shocking and problematic -- and thus the most pregnant -- characteristic of Psi is its *apparent independence of time* as well as space. Experimentally, for example, it does not seem to matter much whether a remote viewing takes place before, during, or after the viewed event, whether nearby or at a great distance (Radin, 1997a). Persistent evidence suggests strongly that thinking about these phenomena in terms of the usual notions of cause and effect is not likely to yield new insights -- and may in fact be *the* major impediment to a deeper understanding.

Considered in a more judicious way, Psi phenomena do not necessarily contradict current physical theory, as we will try to elucidate below, and no new forces or fields, information or interaction paths, etc. are required. (Indeed, it is difficult to see how a new force or field could be added at all without greatly upsetting existing theory.) It is only our still largely classical interpretations of both classical and quantum situations which continue to complicate matters. The supposed weirdness of quantum phenomena (for example non-local correlations in an EPR experiment) can be shown to be largely due to unnecessarily restrictive, neo-classical interpretations of the laws of quantum mechanics (Etter & Noyes, 1998; Lindley, 1997).

Perhaps the most important message from Psi experimentation is that our traditional notion of unidirectional causality is inadequate, or perhaps just plain wrong, and a bi- or omni-directional relational approach is more likely to represent physical reality. We tend to reason “A is the cause of B, therefore A must precede B”, when much of physics is already regarded timelessly. This suggests that “A and B interact, are (cor)related, influence each other mutually” is a far more useful conceptualization that is already available, for example in particle interactions represented by Feynman diagrams.

It is also worth noting that the existing laws of both the classical and quantum realms are almost entirely time symmetrical, so order-independent or retro-causal effects ought not to be considered preposterous or problematic. In quantum theory, the wave function is fully symmetrical in time, although its so-called "collapse" under measurement is considered random and irreversible. New approaches are emerging, however, in which measurement can be understood as a time-symmetrical interaction between the quantum and the classical domains, without the mysterious collapse (Etter & Noyes, 1998; Cerf & Adami, 1996a,b).

With the stakes as high as Time, Space, and Causality, it is difficult to overstate the importance of research into Psi phenomena. Progress in this direction may well lead to a reformulation and re-interpretation of quantum theory, and thus to deep reconsideration of parts of physics, but major rewriting is highly unlikely. Even the scientific method itself, based largely on a concept of limited causality and forward influence, may be in need of an overhaul, but this subject is beyond the scope of this paper.

It is also beyond the scope of this paper to consider the large social and cultural implications that would flow from a better understanding of Psi and the quantum realm. Our understanding of the nature and the experience of Psi phenomena are deeply intertwined with our technological culture and its worldview. Arguably, nowhere in the history of mankind has common human experience so strongly conflicted with mainstream scientific opinion. Historically, Psi phenomena have been reported across all cultures, in all eras, and simply haven't disappeared under increasing scientific scrutiny, as many had predicted.

On the contrary, Psi seems to be ubiquitous (usually at a low level), suggesting a deeper reality much like the interconnectedness often associated with eastern “non-scientific” thought and traditions (Jahn & Dunne, 2001). Psi brings us face-to-face with some of the most profound questions of human experience, and challenges our still-young scientific worldview as nothing else has. For this reason, and those above, Psi phenomena deserve more serious attention and scientific study.

Possible explanations for Psi

There are at least three general classes of possible explanations of Psi, and thus three corresponding possible outcomes for research in this still-controversial area:

1. Experiments are wrong and Psi phenomena don't exist. Psi phenomena have been well explored in the laboratory for decades (see for example Bem & Honorton, 1998; Bierman & Radin, 1998; Radin, 1997a; Jahn & Dunne, 1989), and the probability that Psi phenomena are entirely illusory has diminished consistently. Even if it were shown that all past laboratory Psi experiments were somehow flawed, the explanation would have to be highly interesting in itself, and would surely have a significant impact on science as well. Denial of the existence of Psi phenomena seems to be increasingly the refuge of those who are simply not willing to look at the evidence with an open (but still critical) mind.
2. Current physics is deeply flawed and must be entirely replaced in order to accommodate Psi phenomena. It has long been claimed by some that if Psi phenomena are real, then physics as we know it would have to be seriously wrong, or would at least require significant modification. This belief alone has been responsible for much of the unwillingness of mainstream science to look at the evidence for Psi, no less to consider it as important. In particular, precognition would seem to require information transfer from the future, supposedly a logical impossibility. A careful re-reading of existing physics shows that this fear is unfounded, and a major rewrite seems both unlikely and unnecessary.
3. Current physics is adequate to explain Psi, but a deeper understanding and reinterpretation of its foundations are necessary. This is obviously a more appealing alternative, which we describe in part and advocate here. A reinterpretation and a recasting of the physical laws we already have will bring a better understanding of the strangeness of the quantum realm, plus a natural extension into the phenomena of Psi, without requiring dramatic new physics or overturning of well-established laws.

Comparing random bitstreams

Consider the two random bitstreams called **S** (Subject) and **T** (Target) in Figure 1 below. Each is apparently a random sequence, with chance distribution of 0s and 1s. Yet when we compare the two sequences in this example, we find that **S** and **T** are highly correlated, having the same value in 3/4 of the pairs. Of course, even random-appearing bitstreams can be correlated, either by some common dependence or by chance alone.

```

S :      1 0 1 1 0 0 1 0 0 0 0 1 1 1 1 0 0 1 1 1 0 1 0 0 0 1 0 0 1 1 0 1   => 16/32
T :      1 0 1 0 0 0 1 1 0 0 0 0 1 1 1 1 0 1 1 0 0 1 0 1 0 1 0 1 1 1 0 0   => 16/32
R (S=T) : 1 1 1 0 1 1 1 0 1 1 1 0 1 1 1 0 1 1 1 0 1 1 1 0 1 1 1 0 1 1 1 0   => 24/32

```

Figure 1. Two random but correlated bitstreams.

There are many trivial ways in which such a correlation could have occurred without any reduction of the randomness of each individual stream. Figure 2 shows the stream **S** having its origin in common with stream **T** in the past. The XOR function¹ simply inverts every fourth bit as directed by its control (upper) bitstream. There is a lot of “room” in randomness, and random bitstreams may be correlated in subtle and perhaps not-so-subtle ways.

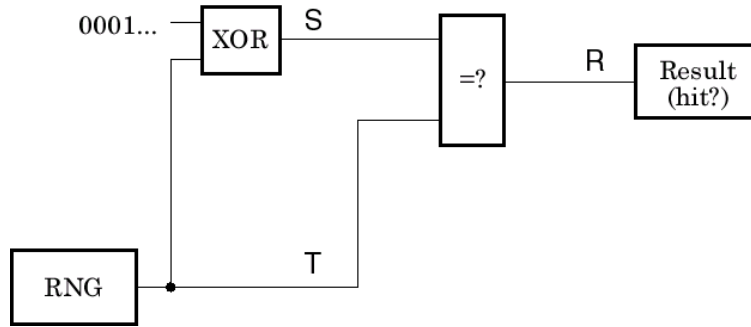

Figure 2. Correlation between **S** and **T** by prior common cause.

A simple Psi experiment

Suppose we construct a simple Psi thought experiment (Figure 3) where a Subject attempts to guess bits generated by a Target random number generator (RNG), a “true-random” source based on quantum phenomena such as radioactive decay. We will assume that the Subject’s guesses are independent and essentially random as well, and thus can also be modeled by a random process, possibly with a slight bias towards 0 or 1. An equality test (comparator) generates the Result bitstream as shown. Usually, the Result stream would be thought of as strictly a function of random variables **S** and **T**, but below we will make assumptions about (place constraints upon) **R** and examine the implications of doing so.

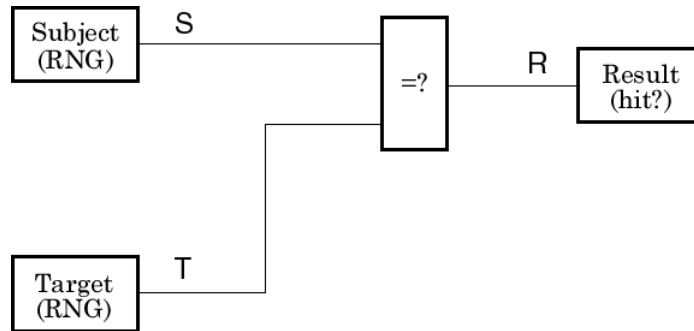

Figure 3. A simple Psi thought experiment.

By construction, no other paths of data flow or influence are present other than those explicitly shown as wires in the diagram. In particular, in this simplified experiment we will not provide any feedback to the Subject from the Result. Streams **S** and **T** are assumed to be independent and random, and thus we would expect a correlation of zero between them, and a 50/50 Result stream.

But suppose the Result (comparison) bitstream shows more hits than would be expected by chance, as Psi experiments often do in the lab. We might then ask how such results came about, and what additional information flow might have been required to bring this about. Do the extra-chance results force us to posit an additional path of influence from Subject to Target (psychokinesis), or from Target to Subject (clairvoyance or precognition, depending on which is chosen first), or along some other path?

Experiment E1: Unbiased Subject - clairvoyance and precognition?

If the Subject bitstream **S** and Target bitstream **T** are indeed random, independent, and unbiased, we would expect to find no long-term correlation between them by chance alone, and the Result bitstream **R** would be uniformly distributed, containing about 50 or so 1's (hits) out of 100 trials. However, if some Psi phenomenon is at work, and the bitstreams somehow become correlated even though individually unbiased (as in the example above), we might see many more hits even as the distributions of **S** and **T** remain the same.

In this somewhat exaggerated example we have assumed 75 hits out of 100 trials², as illustrated by the Link Theory case tables (Shoup & Etter, 1999), i.e. relative probabilities, shown in Figure 4. In these tables, **n** is the relative number of cases having the stated values, and has been normalized to 100 total cases for each of the three bitstreams.

Note that no bias is present in either the Target or the Subject bitstream, and each appears entirely random when examined alone. The lower table in Figure 4 shows conditional probabilities among **S**, **T**, and **R**, and the 50/50 chance distribution for **T** alone obtained by simply combining the relevant cases for **T** = 0 and for **T** = 1.

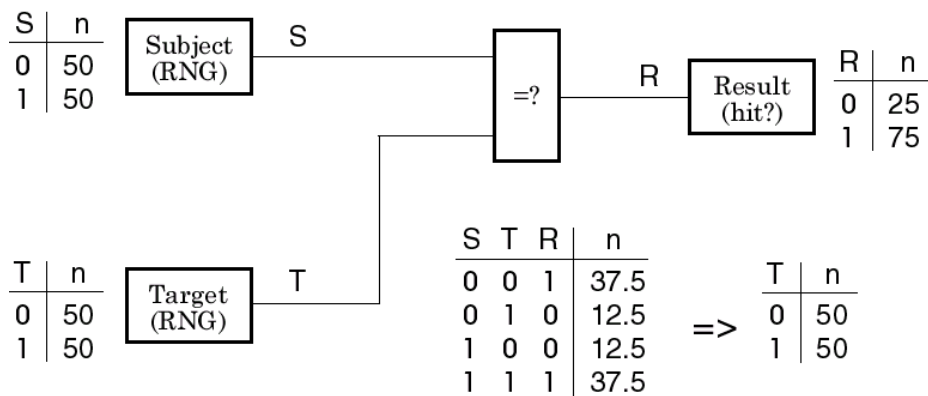

Figure 4. Experiment E1: Random streams with correlation (Psi hitting).

To illustrate using conditional probabilities, we are given $p(S=1) = 0.50$, $p(R=1) = 0.75$, and the equality constraint $(S = T) \Leftrightarrow R$. In the case where streams **S** and **R** are assumed independent, we have³

$$p(R | S) = p(R),$$

that is, **S** by itself tells us nothing about **R**. The conditional probabilities are then

$$p(R=1 | S=0) = p(R=1 \text{ and } S=0)/p(S=0) = p(R=1) , \text{ and} \\ p(R=1 | S=1) = p(R=1 \text{ and } S=1)/p(S=1) = p(R=1) .$$

So for the cases where $R = 1$, namely $T = S = 0$ and $T = S = 1$,

$$p(T=0 \text{ and } S=0)/p(S=0) = p(R=1) , \text{ and} \\ p(T=1 \text{ and } S=1)/p(S=1) = p(R=1) ,$$

and for the cases where $R = 0$ similarly,

$$p(T=1 \text{ and } S=0)/p(S=0) = p(R=0) = 1-p(R=1) , \text{ and} \\ p(T=0 \text{ and } S=1)/p(S=1) = p(R=0) = 1-p(R=1) .$$

So then, solving in all four cases,

$$p(T=0 \text{ and } S=0) = p(S=0)*p(R=1) = 0.50*0.75 = 0.375 , \\ p(T=1 \text{ and } S=1) = p(S=1)*p(R=1) = 0.50*0.75 = 0.375 , \\ p(T=1 \text{ and } S=0) = p(S=0)*(1-p(R=1)) = 0.50*0.25 = 0.125 , \\ p(T=0 \text{ and } S=1) = p(S=1)*(1-p(R=1)) = 0.50*0.25 = 0.125 ,$$

and it follows by combining like cases that⁴

$$p(T=0) = p(T=0 \text{ and } S=0) + p(T=0 \text{ and } S=1) = 0.50 , \text{ and} \\ p(T=1) = p(T=1 \text{ and } S=0) + p(T=1 \text{ and } S=1) = 0.50 .$$

Discussion of experiment E1

Upon reflection after the experiment is over, it is easy to see that given the stated Result distribution (75/25) and the assumption of unbiased (50/50) Subject and Target, *some correlation must have been present* between the Target and the Subject streams in this experiment. It is usually asked: How did this correlation occur? A more interesting question, seldom asked, is: Was it this unexpected correlation between **S** and **T** that produced the high Result, or the unusual Result that produced the correlation?

Clearly neither alternative alone captures the full symmetry of the situation. (It is exactly this limitation in the usual assumption of forward causality that we wish to

highlight.) It might be that **S** and **T** were somehow mysteriously connected, and affected one another directly. But our intention is to show here that a constraint or influence exerted on **R** alone would also have given the same overall results due to the freedom present in the random sequences **S** and **T**, and that this is a simpler explanation having other desirable properties as well.

A more useful interpretation of this experimental arrangement is that the three variables participate *jointly* in the three-way equality relation, which is in principle a tri-directional constraint. If we see extra-chance Results, *no additional causal path between S and T need be present* in order for this outcome to have occurred. The apparent clairvoyance or precognition is merely a consequence of the distribution on **R** and the symmetry of the equality relation. And after the experiment is complete, no further explanation is necessary, since all the data is “in the past”.

Experiment E2: Biased Subject - psychokinesis?

Now suppose that the same high Result is seen (75% hits), but that for some reason the Subject's guesses happened to be slightly biased, 52 0's for every 48 1's (Figure 5). With this additional constraint on **S** in place, a tabular analysis or a conventional conditional probability calculation just as before shows that the Target generator must also have been slightly biased, 51 to 49.

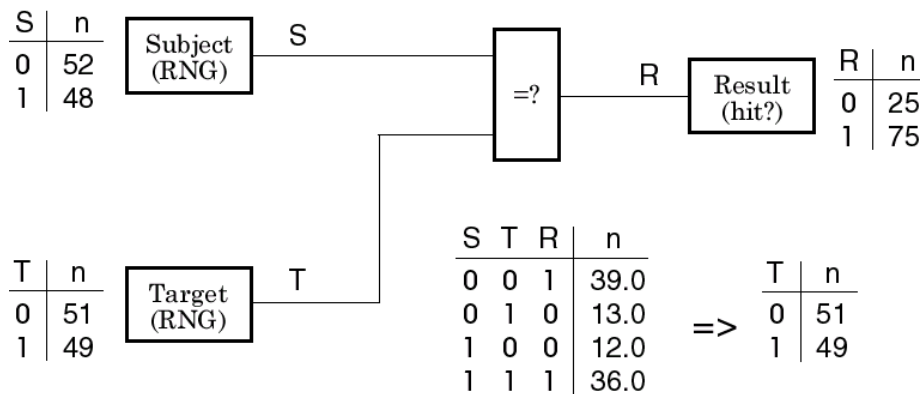

Figure 5. Experiment E2: Bias in the Subject influences the Target RNG.

By calculations identical to those for E1 above, but this time given $p(S=0) = 0.52$ and $p(S=1) = 0.48$, we deduce that

$$p(T=0) = p(T=0 \text{ and } S=0) + p(T=0 \text{ and } S=1) = 0.39 + 0.12 = 0.51 \text{ , and}$$

$$p(T=1) = p(T=1 \text{ and } S=0) + p(T=1 \text{ and } S=1) = 0.13 + 0.36 = 0.49 \text{ .}$$

In other words, *it appears as if the Target RNG is being influenced*, somehow pulled away from a 50/50 random distribution as if by a psychokinetic mechanism. It is natural to infer that some influence on the Target generator must have occurred, yet no extra path or external interference with **T** is necessary to produce this effect. The outcome can be

simply explained as a consequence of the statistical constraints that we imposed on the distributions of **S** and **R**, and the statistical freedom already available in **T**.

Is the tail wagging the dog? The point again in this case is that the three variables **S**, **T**, and **R** are *jointly* constrained by the equality comparator, and the apparent psychokinetic mechanism is just this constraint acting *in both forward and backward directions*. Note also that if the constraint on the independence of **S** and **R** were relaxed, more freedom would be available to **T**, and its bias would not be necessary.

Further discussion of the experiments

Of course, it is also important to ask, if the **S** and **T** streams are indeed random and unavailable to each other, how did the extra-chance Result we assumed in **R** come to be? One reasonable answer is that some influence is exerted “backwards” by the (potentially large number of) things to which **R** is attached. *Anything which depends upon or would be affected by the outcome of the experiment has an interaction with it*, and thus, by symmetry, the potential to affect it. How exactly the Subject, the experimenter, the environment, or other agents may have influenced the results of the experiment in this way is the subject of further research.⁵

If the ideas of future constraint and backwards causality are disturbing, it is useful to recall and compare another well-established way of reasoning in physics, the principle of *least action*. This principle, which has been shown to be essentially equivalent to Newtonian mechanics, is based upon two boundary conditions, one of which is the final state of the system at some time in the future. See Price (1996) for useful examples and discussions of least action, backward causality, and our common assumptions about time (but without any discussion of Psi).

Psi without rewriting Physics?

To summarize, in the simple bit-guessing Psi experiments above, we assumed two boundary conditions, one on the distribution of the Result and then additionally one on the distribution of the Subject's guesses. The former could be said to have been “a constraint on the future” prior to the experiment, but was “the way things turned out” afterwards. Assuming provisionally that the Subject was the agent, in some sense responsible for the unusual outcome, what path did he utilize to bring about these overall results, especially the apparent deviation from randomness in the Target stream in experiment E2?

To put it another way: Suppose that a Psi experiment of this type has been conducted, and all data have been recorded. Suppose that we see some extra-chance results, and thus a corresponding unexpected correlation between **S** and **T**. How did this occur?

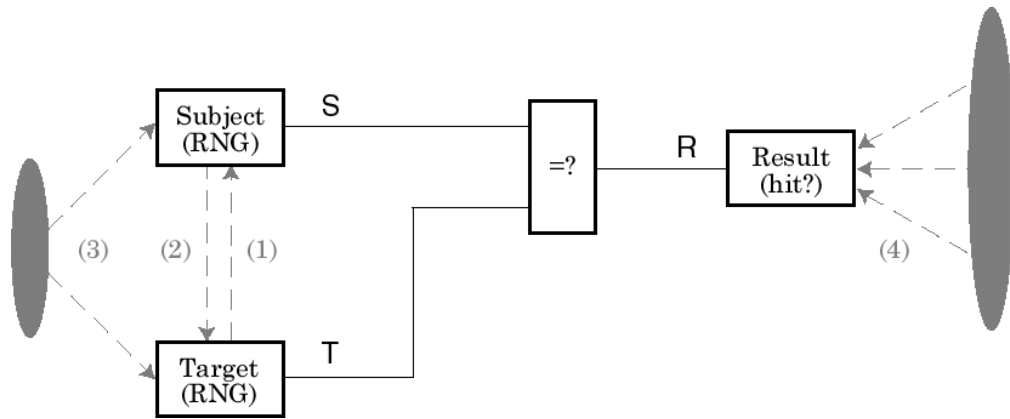

Figure 6. Possible paths to bring about correlation.

Restricting ourselves to the usual sort of causal reasoning, there are 4 possibilities as shown in Figure 6:

1. *The Subject was somehow able to sense the Target bits or the (future) Results and adjust his guesses accordingly.* This is the standard clairvoyance (**T** chosen before **S**) or precognition (**S** chosen before **T**) explanation. The mechanism would have to include a previously undetected influence by some means using an undiscovered human sensitivity or sense organ. This doesn't seem very plausible, yet it is still a commonly accepted hypothesis about how Psi must work. Moreover, if the Target bit is chosen first, then the Subject must possess some precognitive ability, and this requires information flow backwards in time. Naturally, physicists are typically quite skeptical of an explanation of this sort, and thus even of the existence of the phenomenon itself.
2. *The Subject was somehow able to affect the Target generator directly.* This is the usual psychokinetic explanation, as apparently seen in experiment E2 above and many careful real-world experiments (Jahn & Dunne, 1989; Jahn et al, 2000). Quantum processes now considered to be in principle random would have to be influenceable, and information conveyed in some currently unknown way. Again, a new or unappreciated mediation by a force or field would seem to be necessary -- unlikely in the face of existing physical evidence and well-tested quantum theory.
3. *The Subject was somehow able to make use of prior correlations or entanglement between himself and the Target generator to make or adjust his guesses, similarly to 1 above but conditioned by past common cause.* (See the similar example given previously.) After all, real RNGs have a physical history, and their performance may not be entirely isolated from the past, as we have assumed. According to current cosmological theory, everything has interacted in the past, even if quite remotely. It is generally assumed that any residual correlations between well-separated objects has long ago been erased by unavoidable decoherence at ordinary temperatures, but this seems far from conclusively established.⁶ While this hypothesis might explain

clairvoyant or precognitive effects, some way to *affect* quantum random sequences would still be required in order to explain psychokinesis of the sort seen in experiment E2 above and in laboratory experiments.

4. *The Subject was somehow able to affect the Result by interactions in the future* that were then reflected backwards through the equality constraint to affect the Target generator (symmetrically to hypothesis 3 above, but relying on a future correlation). This is the hypothesis we have explored in the calculations above by placing a constraint on the Result bitstream.⁷

With hypotheses 1 and 2, an extra unknown path of information or influence is necessary between **S** and **T**, and this seems to be in serious conflict with well-established physical theory. Alternatives 3 and 4 however do not require any such mysterious paths nor the difficulties associated with them.

In particular, hypothesis 4 can readily account for many if not all of the so-called clairvoyant, precognitive, *and* psychokinetic effects apparently exhibited in such experiments, without new paths or any major insult to well-accepted physical law -- if we allow symmetrical (bidirectional) causality. Even the apparent “pulling” of the Target RNG in experiment E2 is possible via influence on its existing “output”, without requiring some new and separate mechanism or path.

A requirement of hypothesis 4, of course, is some way for the Subject (or the experimenter or some other agent) to influence or constrain the future Result via an additional direct or indirect path. Although this cost seems high, even daunting, some form of influence on the Result is actually a simpler explanation for the Psi effects that are in fact seen even under stringent laboratory conditions.⁸ As discussed above, it might be that the Result is affected by a diffuse collection of future backward influences that combine to give the observed overall effect (Etter, 1977). The analogy is sometimes given (Price, 1996) of the time reversal of dropping a stone into a pond, whereby small precise disturbances made at the edges of the pond with just the right timing could converge and cause a highly improbable splash to suddenly emerge from the center. Serious exploration of this possibility undoubtedly will require some extensions to existing mathematical tools and theory (Etter, 2001).

Hypothesis 3 can be tested, to a certain extent, by simply looking for correlations among unrelated RNGs.⁹ Hypothesis 4 can be tested by looking for the presence of corresponding Subject and Target biases in guessing experiments that have shown significant Psi functioning. These two hypotheses are among those now being explored in Internet-based and other experiments (see www.boundaryinstitute.org).

The connection to quantum nonlocality

With a simple rotation, the experimental diagram above gives something quite suggestive of an EPR (Einstein, Podolsky, Rosen) arrangement (Bell, 1964). See Figure

7. If we constrain the Result stream to be all zeros (continual missing), then the Subject and Target streams must be perfectly anti-correlated, just as in the case of the spins of an entangled EPR particle pair (Aspect, 1982).

In the usual EPR experiment, the “Result” constraint discussed here is instead thought of as a *preparation*, since it occurs *prior* to measurement of the Subject and the Target spins. But our point here is that *time sequence is not relevant to correlation*. Because of the equality constraint, the **R**, **S**, and **T** streams are jointly constrained no matter what their time sequence. With respect to the Psi experiment, the usual EPR arrangement is just a special case, namely complete entanglement at the “source” (**R** in this case) followed by measurement at **S** and **T**, in either order.

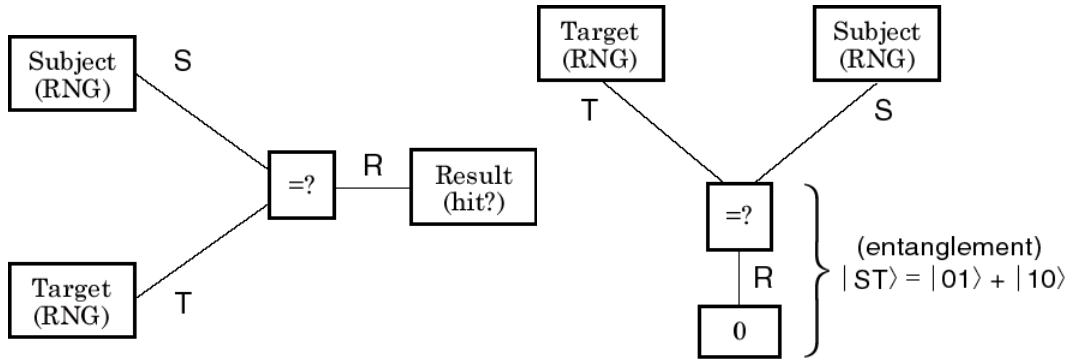

Figure 7. Rotation of the simple Psi experiment suggests an EPR arrangement.

While the similarity here is not trivial, we hasten to add that this simple binary Psi experiment does not capture the full generality of the non-local phenomena demonstrated in EPR arrangements. In particular, there is no provision here for (independent) rotation of the measuring devices at **S** and **T**, which are required to demonstrate violations of Bell's inequalities. We have carried out a more complete Link-Theoretic analysis that explains EPR in detail (Etter & Noyes, 1998), including the inequality violations, but the analysis is beyond the scope of the present paper. The deeper connection between RNG-based experiments and quantum nonlocality is a subject of ongoing research.

What is an RNG anyway?

According to current quantum theory, there are "causeless" *uninfluenceable* events -- events that happen purely at random. These include radioactive decay, thermal noise fluctuations, and measurements of superposed quantum states. Quantum theory remains silent on just how this happens, and how a particular outcome is chosen from those that are possible in a given superposition. In truth, an *assumption* of randomness has been included at the core of quantum theory out of necessity and because of its success in describing observed statistical behavior in the physical world.

Since a “random” choice apparently occurs in a quantum measurement, we naturally ask *where does the information come from* which determines this choice, and how does it

enter the situation? Does a bit of information come from God himself for each “collapse” of a binary variable? Before the measurement, there are two possibilities extant, and afterwards one has been distinguished. This distinction requires a bit of information, not just a reduction in entropy.¹⁰ See Etter & Noyes (1998) and Cerf & Adami (1996a,b) for attempts at explanation of quantum measurement in entirely unitary form, without the miraculous collapse.

The thought experiments E1 and E2 discussed above might suggest that a true random number generator is *not* merely *producing* values with a given distribution, but is somehow at least in part *reflecting* the biases in its future environment. As a further speculation, perhaps a quantum-random process in this situation is an entirely free variable that does nothing but satisfy the constraints and influences it sees via its “output” connections -- literally the tail wagging the dog. Most such processes see a very large number of particles and interactions at their outputs, and so would typically show near-chance behavior due to large-number effects.

In the latter experiment E2 above, we have somewhat constrained both **S** and **R**. Thus a random element such as **T** *has no choice* but to produce the distribution of values shown. If an RNG is indeed a “causeless” random data source (one having no inputs or internal memory), then how could it be otherwise? The alternative would be for the quantum process to have some internal mechanism that *ensures* a uniform distribution, and this contradicts the assumptions of fundamental randomness.¹¹

What then about Causality?

The concept of causality should be generalized, and replaced in our thinking and in our vocabulary by symmetrical, less restrictive concepts such as *influence*, *dependence*, and especially *correlation* or *joint constraint*. Despite our everyday experiences with objects and events, much of physics theory already holds that causality is bi- or omni-directional, and in principle timeless. Our common-sense unidirectional notion of cause and effect has been developed (evolved?) through years of experience in the macroscopic world. But, as we have learned repeatedly (cf. Relativity), our common sense has limited applicability, and it may in fact have deeply and similarly misled us about the true nature of things.

It is perhaps due to our pragmatic human nature that the basic concepts of quantum theory are still defined in terms of our classical intuitions of objects, causes, space, and time. The possibility of an ultimately simpler explanation surely lies in giving up our unwarranted assumptions about unidirectional forward causality, as we have tried to suggest in these examples.

Summary & Conclusions

In this paper we have tried to give evidence for the hypothesis that so-called psychic or Psi phenomena can be understood simply, without any major rewriting of modern physics. We have here and elsewhere (Etter, 1960; Etter & Noyes, 1998; Shoup & Etter, 1999; Etter, 2001) begun to show how a new foundation may be laid underneath current physical theory. This new foundation we hope can be used to give far more cogent explanations for existing quantum phenomena, as well as to predict and explain more elusive phenomena such as randomness and Psi. By altering our notion of causality and taking full account of both forward and backward influence, many of these seeming mysteries will become understandable. The most important ingredient of this new approach is *timeless, relational* thinking.

While a better understanding of Psi phenomena will undoubtedly have a major effect on science and on society, the importance of Psi in the quantum realm alone could be large even in the short term. The exciting possibility and embryonic reality of quantum-mechanically based computers is surely relevant here, since the unusual states of matter which are being created and employed in quantum computing may well be closely connected to those which mediate Psi, namely highly-entangled, multiply-constrained states. It may be that odd, unexpected Psi-like phenomena are already being seen or overlooked in quantum computing laboratories.

We believe the study of Psi phenomena, both theoretically and experimentally, is among the most important activities that can be undertaken within science today. The issues here concern not just the fundamentals of physics, but also the larger phenomena of consciousness, and ultimately the nature of reality itself.

Acknowledgements

I am indebted to Interval Research Corporation and especially David Liddle for support of this work. I also wish to thank my Boundary Institute colleagues Thomas Etter, Dean Radin, and Edwin May for many spirited discussions on these topics, and Bernard Haisch for many useful comments.

References

- Aspect, A., Dalibard, J., and Roger, G. (1982). "Experimental Test of Bell's Inequalities Using Time-Varying Analyzers", *Phys. Rev. Letters*, Vol. 49.
- Bell, J. S. (1964). On the Einstein Podolsky Rosen paradox, *Physics*, 1, 195-200.
- Bem, D. J. and Honorton, C. (1994). "Does Psi Exist? Replicable Evidence for an Anomalous Process of Information Transfer", *Psychological Bulletin* 115, No. 1.
- Bierman, D. & Radin, D. I. (1998). "Anomalous unconscious emotional responses: Evidence for a reversal of the arrow of time", in *Tuscon III: Towards a Science of Consciousness*, MIT Press.
- Cerf, N., and Adami, C. (1996a). "Quantum Mechanics of Measurement", available at xxx.lanl.gov as quant-ph/9605002.

- Cerf, N., and Adami, C. (1996b). "Quantum Information Theory of Entanglement", available at xxx.lanl.gov as quant-ph/9605039.
- Deutsch, David (1997). *The Fabric of Reality*, Penguin USA.
- Etter, Thomas (1960). "On the Occurrence of Some Familiar Processes Reversed in Time", unpublished manuscript, © Copyright 1960, Thomas Etter. [*]
- Etter, Thomas (1977). "Survey of Mathematical Theory of Paracausality", unpublished manuscript, © Copyright 1977, Thomas Etter. [*]
- Etter, Thomas, and Noyes, H. Pierre (1998). "Process, System, Causality, and Quantum Mechanics: A Psychoanalysis of Animal Faith", Stanford Linear Accelerator Center Publication 7890, revised in *Physics Essays*, 12, 4, Dec. 1999. [*]
- Etter, Thomas (2001). "Reflections on PSCQM", in Noyes, H. Pierre (2001) *Bit-String Physics: A Finite and Discrete Approach to Natural Philosophy*, World Scientific [*]
- Jahn, R.G., and Dunne, B. (1989). *Margins of Reality*, Harcourt Brace.
- Jahn, R.G., and Dunne, B. (2001). "A Modular Model of Mind/Matter Manifestations (M^5)", *Journal of Scientific Exploration*, 15 (3).
- Jahn, R., Mischo, J., Vaitl, D., et al (2000). "Mind/Machine Interaction Consortium: PortREG Replication Experiments", *Journal of Scientific Exploration*, 14, 4.
- Lindley, David. (1997). *Where Does the Weirdness Go?*, HarperCollins.
- Price, Huw (1996). *Time's Arrow and Archimedes' Point*, Oxford University Press.
- Putnam, H. (1979). "A Philosopher Looks at Quantum Mechanics", *Philosophical Papers, Vol. I, 2nd ed.*, Cambridge University Press.
- Radin, Dean I. (1997a). *The Conscious Universe*, HarperEdge.
- Radin, Dean I. (1997b). "Unconscious perception of future emotions: An experiment in presentiment", *Journal of Scientific Exploration*, 11 (2). [*]
- Schmidt, Helmut (1975). "Toward a Mathematical Theory of Psi", *Journal of the American Society for Psychical Research*, 69 (4).
- Schmidt, Helmut (1978). "Can an Effect Precede Its Cause? A Model of a Noncausal World", *Foundations of Physics*, 8 (5/6). [www.fourmilab.ch/rpkp]
- Schmidt, Helmut (1993). "Observation of a Psychokinetic Effect Under Highly Controlled Conditions", *Journal of Parapsychology*, 57. [www.fourmilab.ch/rpkp]
- Shoup, Richard, and Etter, Thomas (1999). "Link Theory - From Computation to Quantum Physics, Parts I & II", in *Aspects II*, Proc. Alternative Natural Philosophy Assn. 20, ANPA. [*]

[*] Paper available on the Boundary Institute web site www.boundaryinstitute.org.

¹ eXclusive OR: $XOR(A,B) = (\text{not}A \text{ and } B) \text{ or } (A \text{ and } \text{not}B)$. If A is 1, then the output is notB.

² Of course, in the laboratory we do not see performance at the 75% level in Psi experiments of this general type, unfortunately -- or perhaps fortunately. But consistent, small extra-chance results do occur and have been observed over large numbers of trials and many experimental replications (Jahn & Dunne, 1989; Radin, 1997a). It remains a significant puzzle (and an important clue) as to why, if indeed there can be consistent low-level Psi, there isn't *more*. The survival value to evolving life forms would be very high indeed.

³ Here we use bold **S**, **R**, and **T** to refer to the streams, and plain S, R, and T to refer to individual bits in those streams.

⁴ The beauty of Link Theory is that all of these relationships are immediately captured by simply “linking” together the S, T, R, and equality tables to form the composite table STR as shown (Shoup & Etter, 1999; Etter & Noyes, 1998).

⁵ The general idea of future constraints affecting the past and the connection to Psi phenomena apparently originated in the 1960s with Helmut Schmidt (1975, 1978) and Tom Etter (1960, 1977), independently.

⁶ Recall also that significant ensemble correlations may exist among N variables that cannot be seen by examining any N-1 or fewer of them, by generalization from the example in the previous section. This means that such correlations of many particles could remain almost entirely hidden and yet have real large-scale effects in the world.

⁷ See Etter (1977) and Schmidt (1978) for previous work and discussions of future constraint and “kickback” effects.

⁸ See Schmidt (1993) and Radin (1997a) for full descriptions of several such experiments, including some with prerecorded random data.

⁹ See the Global Consciousness Project (noosphere.princeton.edu) for an interesting and provocative effort in this direction with an established network of RNGs and data readily available. See also www.boundaryinstitute.org/randomness.htm.

¹⁰ Of course, there is one well-known way out of this conundrum, but the price is very high indeed: the multiple-universe interpretation of quantum theory (Deutsch, 1997). But the multiple *values* paradigm already embedded in the traditional idea of superposition seems entirely adequate when properly interpreted, and is certainly simpler.

¹¹ But it bears repeating again that significant extra-chance deviations from randomness *are* seen in carefully-controlled real-world experiments, and thus some explanation is necessary.